

Impedance to Frequency Relationship of a Speaker

Eric Hofesmann

College of Charleston Department of Physics and Astronomy

(Dated: March 28, 2016)

The impedance of two dual driver speakers, of nominal impedance $6\ \Omega$ and $8\ \Omega$, was determined on the range of frequencies of human hearing, from 10 Hz to 14 kHz. Ohm's Law was used to calculate the impedance, ranging from $5\ \Omega$ to $40\ \Omega$, of the speakers by measuring the voltage drop and current. Two impedance peaks were found in a closed case speaker while a third, 60 Hz peak was found in an open, ported speaker. Using an oscilloscope, a phase shift was measured which reached zero during the impedance peaks and troughs. An equivalent circuit was simulated which showed a phase shift similar to the experimental data. A $6\ \Omega$ impedance was measured for the $6\ \Omega$ speaker but a $5\ \Omega$ impedance was measured for the $8\ \Omega$ speaker.

I. INTRODUCTION

An audio speaker generally includes a nominal impedance value that is used by audio enthusiasts to determine the correct amplifier to use in conjunction with the speaker [1]. If the impedance is too low for an amplifier then the current will increase and possibly damage the hardware. The amount of current, I , passing through the amplifier in terms of resistance and voltage, V , is given by Ohm's law. However, speakers include components that limit current other than just resistors. Ohm's law can be generalized in terms of impedance, Z , to also include these reactive components.

$$Z = \frac{V}{I} \quad (1)$$

A. Drivers

When only an individual audio speaker is used, it is called a driver [2]. Drivers have a range of frequencies that they can emit but this range generally does not cover all of human hearing. To counteract this, multiple drivers can be used in conjunction, each covering a separate frequency range. A high frequency driver is called a tweeter and a low frequency driver is called a woofer.

B. Crossover

Capacitors and inductors are used to cross over from one driver to another since they are designed to allow current to pass only along specific frequency levels. They can in effect be used as a switch turning on one driver and turning off another [3].

Figure 1a shows a circuit diagram of a low pass filter created from an inductor and a capacitor. This can be used to only allow low frequencies up to a certain point to pass through after which the signal dies off. This point can be changed through the inductance and capacitance of the components used. Similarly, a high pass filter, as shown in Figure 1b, can be made by reversing the

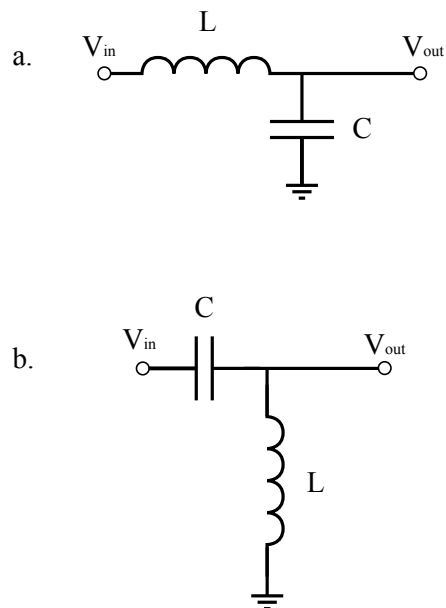

FIG. 1. An LC low pass filter is composed of an inductor in parallel with a capacitor as seen in a. An inductor limits current flow at high frequencies and a capacitor limits current flow at low frequencies. An LC high pass filter is composed of a capacitor in parallel with an inductor as seen in b. An inductor limits current flow at high frequencies and a capacitor limits current flow at low frequencies.

capacitor and inductor [4]. This circuit will only allow high frequencies through.

When dealing with reactive components, there will be a shift in the phase of the signal [5]. In capacitive elements, the voltage will lag the current by a maximum of $\pi/2$. In inductive elements, the current will lag the voltage by a maximum of $\pi/2$.

II. EXPERIMENTAL PROCEDURE

Two commercial speakers were used, the Sony SS-H414 and the Realistic 40-2030B. The Sony speaker is rated at a nominal impedance of $6\ \Omega$ and the Realistic speaker has a nominal impedance of $8\ \Omega$. Both are dual driver speak-

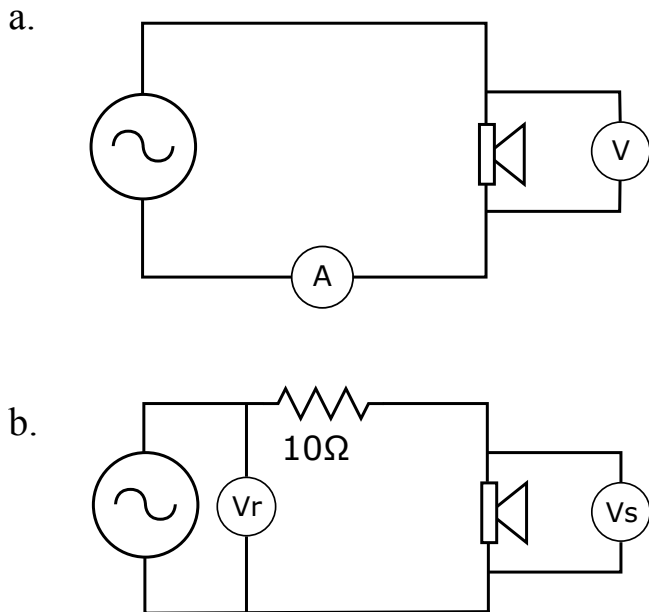

FIG. 2. The initial experimental setup is shown in a. An AC power supply with variable frequency gives a sinusoidal signal. A speaker is attached in series with an ammeter to measure the current in the circuit. A voltmeter is connected before and after the speaker to measure the voltage drop over just the speaker. To measure the phase shift of the speaker, the voltage coming from function generator is measured over the resistor as seen in b.

TABLE I. This table shows the range of values recorded for each speaker. The currents and voltages are RMS values taken from the multimeter. The frequencies were read directly off of the function generator.

Variable	Sony Speaker	Realistic Speaker
V	74.25 mV - 316.8 mV	66.67 mV - 231.3 mV
I	7.945 mA - 12.587 mA	9.54 mA - 12.15 mA
f	10 Hz - 14.04 kHz	42 Hz - 10 kHz

ers including a tweeter and a woofer. The values required to create an impedance versus frequency curve are only current, voltage, and frequency. The current and voltage are used in Ohm's law to calculate impedance at different frequencies. The signal was created and frequency recorded by the function generator and the current and voltage were measured using a multimeter as seen in Figure 2a.

A phase shift can also be measured using the setup in Figure 2b. The resistor allows the recording of the current in the circuit but since the oscilloscope probes were connected to the same ground as the function generator, V_r had to be taken across both the resistor and the speaker. V_r is related to V_s where the difference between the signals shows the phase shift caused by the speaker.

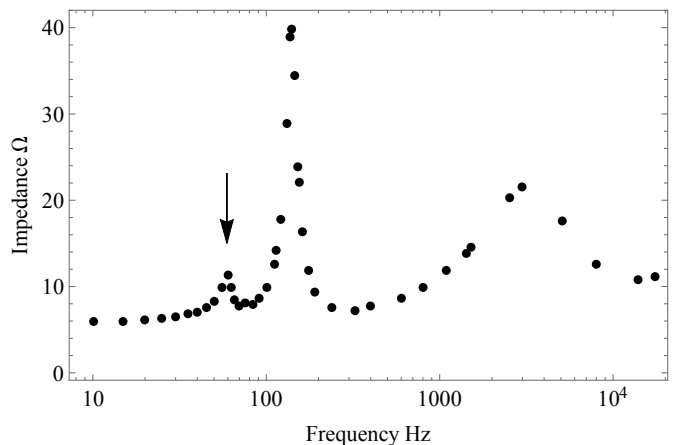

FIG. 3. The impedance as a function of frequency of the Sony speaker, nominal impedance of 6Ω , was calculated from the measured voltage and current values. There were three peaks at 60 Hz, 140 Hz, and 3 kHz.

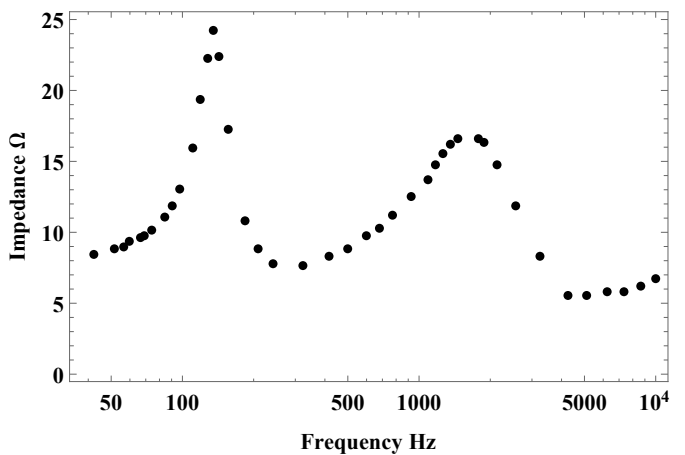

FIG. 4. The impedance of the Realistic speaker, nominal impedance of 8Ω , was calculated at each measured point from the recorded current and voltage. There are two peaks centered at 140 Hz and 1500 Hz

III. RESULTS

The DC voltage was originally set to around 300 mV. This fluctuates as the resistance of a circuit changes. Table 1 shows the range of values of voltages, current, and frequencies measured for the Sony and Realistic speakers.

Figure 3 shows the plot of impedance versus the frequency of the input signal. There are three peaks at 60 Hz, 140 Hz, and 3 kHz. The impedance ranges from 6Ω to 40Ω . Figure 4 is the impedance graph of the Realistic speaker which has similar features. Instead of three peaks, it contains two peaks centered at 140 Hz and 1.5 kHz. The impedance values range from 5Ω to 25Ω .

The Sony and Realistic speakers were similarly built with one exception, the Sony speaker had a 3 cm diameter hole in the back of it where the wires came out,

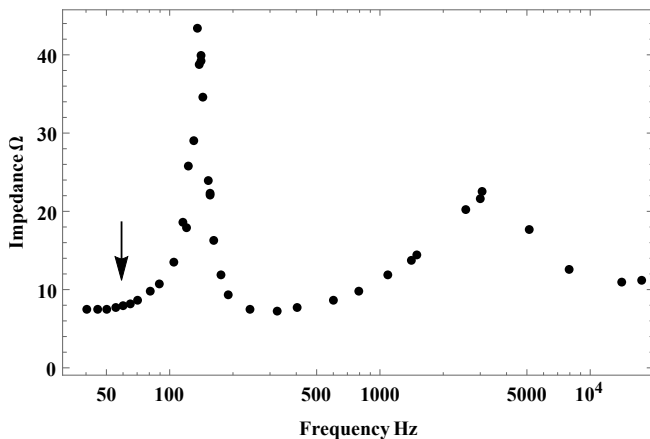

FIG. 5. The port in the back of the Sony speaker was filled with dense paper, the impedance curve was measured again. The initial peak vanished and the remaining two were unchanged.

called a port [6]. A hole like this will create a resonance within the case. This hole was covered and then the peak disappeared, as seen in Figure 5.

An equivalent speaker circuit was simulated in MultiSim Blue [7] to determine the reproducibility of the results. The circuit diagram can be found in Appendix B. Figure 7 shows that this simulation also contained the peaks in impedance similar to those found experimentally. V_s can be seen peaking at 26 Hz in the second waveform of Figure 7. This occurred one more time at 3 kHz, much like the experimental data in Figure 5.

Figure 6 and Figure 7 show that the current initially leads the voltage, then they become in phase, then the voltage leads the current, and then they are in phase again. This cycle repeats for each impedance peak. The crossover circuit is causing the current to pass through the varying capacitors and inductors and changing the phase. Before an impedance peak, the signal is passed through the capacitor which is filtering out the low frequencies and the current leads the voltage. As the frequency reaches the peak, the capacitor filters out less and

less of the signal and the phase shift reaches zero. Then after the peak, the inductor begins to filter out the higher frequency signals and the voltage now leads the current.

A. Error Analysis

The sources of measurement error could only come from the two variables, current and voltage. The current and voltage were taken using a Fluke multimeter. An oscilloscope was used only as a visual representation of the changes occurring in voltage. The accuracy of the multimeter reading varied with frequency. The uncertainty in measurement was calculated in Appendix A.

Figure 3 shows that the impedance of the realistic speaker dips to nearly 5 Ω . The minimum value of the speaker should only be 8 Ω since it is rated at that impedance. This is likely due to the multimeter error once in the kilohertz range which is reported in the manufacturers manual [8]. Both the current and voltage readings have an error in this range, thus the error in impedance will be compounded. Appendix A shows the calculation showing that the impedance can be nearly 6 Ω . These data are still 2 Ω less than the rated impedance and seem to be outliers since the other dips in impedance at 40 Hz and 300 Hz both go to expected minimum of 8 Ω .

IV. CONCLUSION

The impedance peaks are at the frequencies where each driver reaches its maximum sound output. At these points is where the phase shift goes to zero. This can physically be described by the capacitor and inductor in the crossover circuit being in resonance with one another which leads to be a maximum impedance.

For consumers, an ideal impedance curve would be a flat line. This gives the most constant sound throughout the entire frequency range but it is fairly difficult and expensive to produce drivers without an impedance peak.

-
- [1] Sony SS-H414 Speaker Manual
 - [2] Joel Müller, *Audio Speakers and Relation to Physics*, Hesston, 2015, <http://www2.hesston.edu/Physics/AudioSpeakers/PHYSICS.HTM>
 - [3] Arthur Berkhoff, *Impedance Analysis of Subwoofer Systems*, 1994, http://doc.utwente.nl/62316/1/Impedance_Analysis_of_Subwoofer_Systems.pdf
 - [4] Marco Carlisi, Mario Di Cola, Andrea Manzini, *An alternative approach to minimize Inductance and related Distortions in Loudspeakers.*, 2005, http://www.eighteensound.com/Portals/0/Img/Img_tech/doc_tech/18_Sound_AIC.pdf
 - [5] Rod Elliott, *Phase Angle Vs. Transistor Dissipation*, ESP, 2005, <http://sound.westhost.com/patd.htm>
 - [6] Claudio Negro on the impedance of a speaker, <http://www.claudionegro.com/sw/swimpedance/speaker/speaker.html>
 - [7] MultiSim Blue Circuit Simulation Software by Mouser Electronics, <http://www.mouser.com/multisimblue/>
 - [8] Fluke Multimeter User Manual, <http://www.fluke.com/>

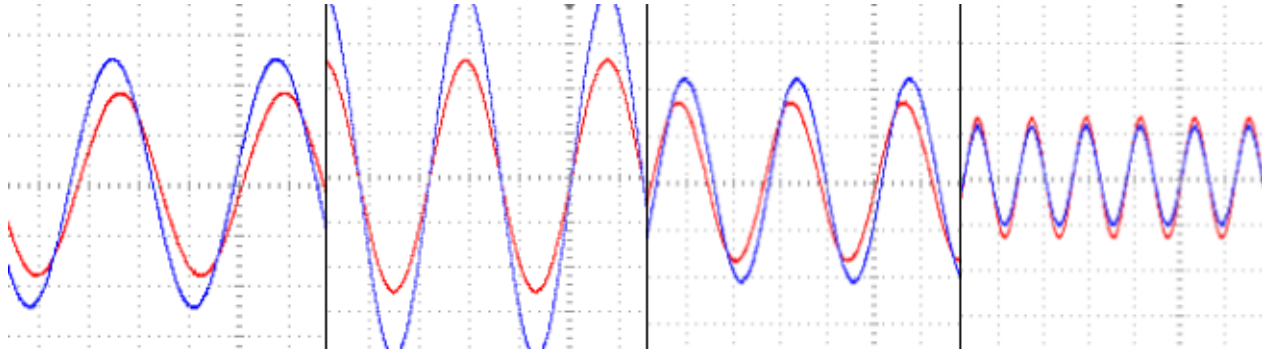

FIG. 6. The voltages from the setup in Figure 2 were recorded from the oscilloscope and four images were edited together. The blue signal, which has a higher amplitude in the first three images and a lower amplitude in the fourth image, is V_s in Figure 2b. The other waveform is the voltage taken across the resistor and the speaker, V_r , which had a less extreme phase shift than V_s . These images are taken around the 140 Hz peak seen in Figure 3. The first, leftmost, image was taken at 122 Hz, the second at 140 Hz, the third at 166 Hz, and the fourth at 333 Hz. Before the peak, the current leads the voltage, at the peak the voltage and current are in phase, then after the peak the voltage leads the current. The fourth image shows the trough where the signals are in phase again but the voltage now has a lower amplitude than the current. This pattern repeats for the second impedance peak.

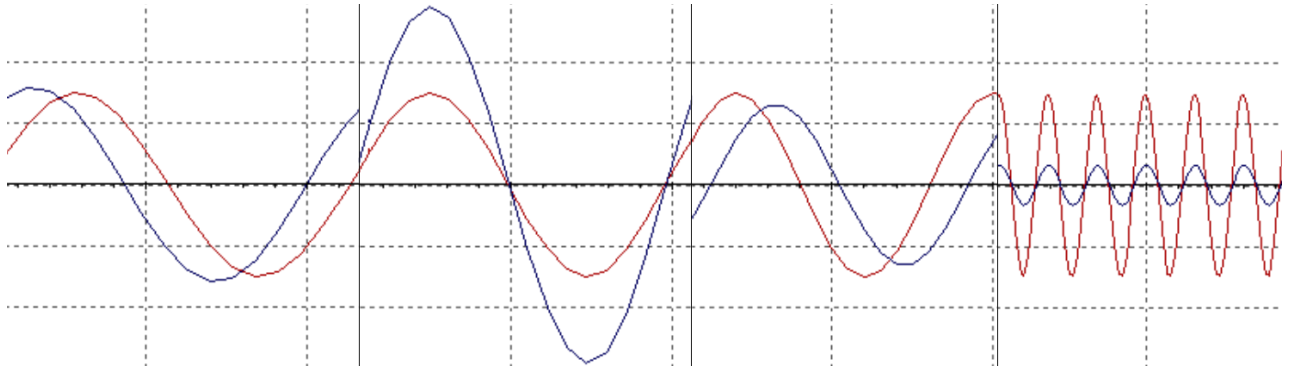

FIG. 7. Four images were taken from the simulation in Appendix B. They were edited together in the same manner as Figure 6. In the first image, V_s leads V_r , in the second they are in phase where V_r has a lower amplitude than V_s , in the third V_r leads V_s , and in the fourth image they are in phase again but V_s has a lower amplitude than V_r .

V. APPENDIX

A. Statistical Methods

The impedance uncertainty at the peaks of the Sony impedance graph were calculated using the Fluke multimeter uncertainties. The uncertainty in voltage is 0.4% + 40 between 45 Hz - 1 kHz and 5% + 40 between 1 kHz - 10 kHz and the uncertainty in current is 0.75% + 20 between 45 Hz - 1kHz and 0.75% + 20 between 1 kHz - 10 kHz.

For the 140 Hz peak impedance voltage of the Sony speaker:

$$V = 316.78mV \times 0.004 + 0.4V = (316.78 \pm 13.07)mV \quad (2)$$

$$I = 7.945mA \times 0.0075 + 0.02I = (7.945 \pm 0.080)mA \quad (3)$$

For the Realistic speakers data points above 5 kHz:

$$V = 67.20mV \times 0.05 + 0.4V = (67.20 \pm 13.07)mV \quad (4)$$

$$I = 12.119mA \times 0.0075 + 0.02I = (7.945 \pm 0.080)mA \quad (5)$$

$$Z = (5.545 \pm 0.361)mA \quad (6)$$

B. Computational Methods

A circuit representing a dual driver loudspeaker, created by Rod Elliott [5], was modeled in the program Multisim Blue [7]. The method used in this simulation mirrored the experimental method. An oscilloscope, function generator, and multimeter were simulated. The phase shift and impedance were simulated using the experimental method by implementing a resistor and simulating V_s and V_a at a range of frequencies.

The circuit is shown in Figure 8.

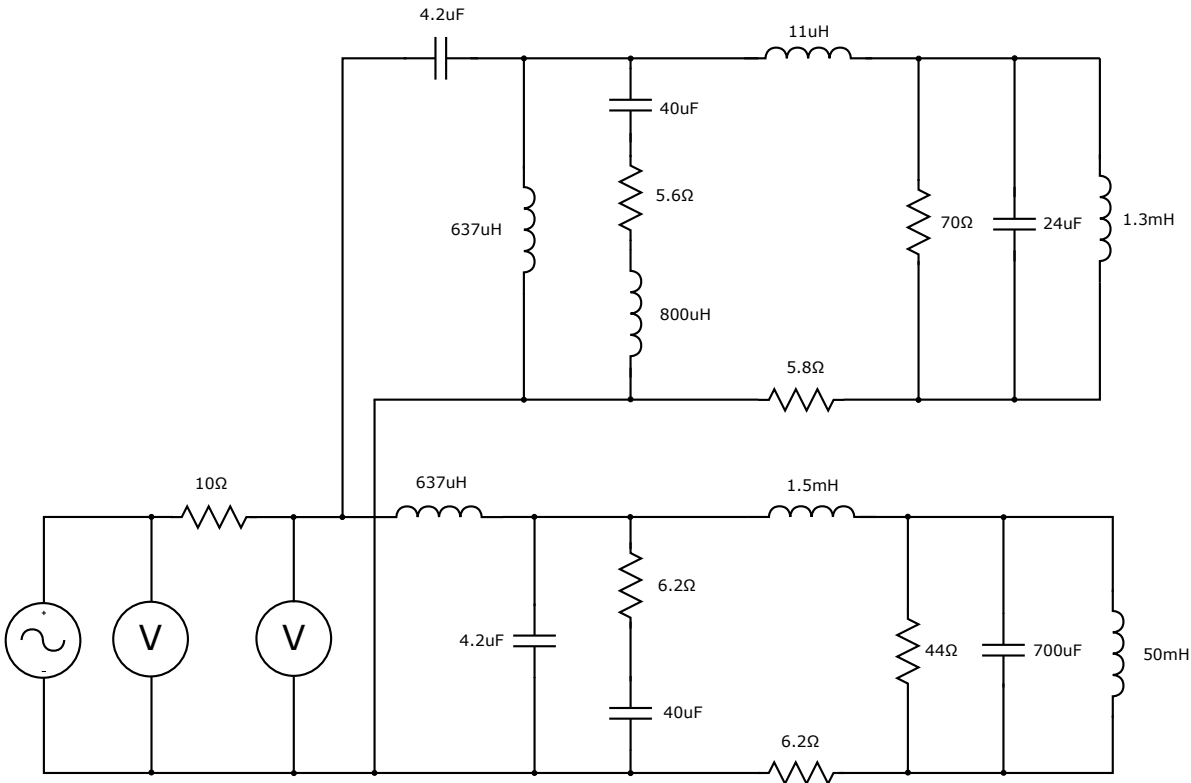

FIG. 8. Circuit representing a dual driver speaker created by Rod Elliott [5]. The voltage differences were taken across just the speaker and across the resistor and speaker. The frequency cutoffs are 65 Hz and at 3077 Hz [5].